

Available as 80kg, 160kg, 230kg and 300kg options with up to 30 metres lifting capacity (see specifications on reverse)



Spring loaded safety lock on top fixing



Built in limiter prevents the hoist overwinding

OPTIONAL EXTRAS

- **Scaffold supported jib arm with 180° rotation**
Load tested to 230kg (not available for 300kg)
- **Pendant control extension**
Plug in for additional 10 metre length

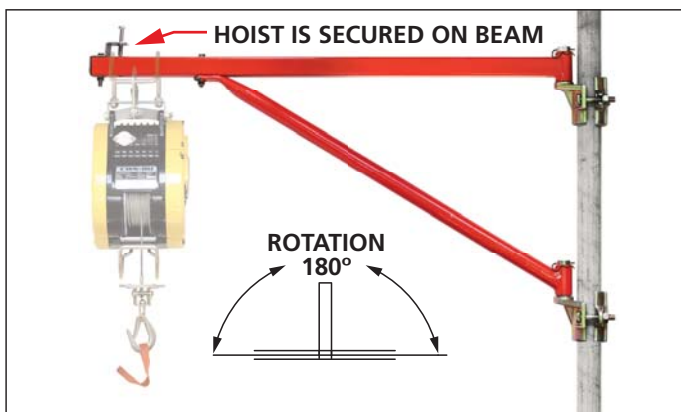

TESTED & CE CERTIFIED BY THE BHW GROUP

Hoists and winches from the **BHW Group** are rigorously tested against competitor brands and CE certified. Our aim is to provide the best machinery suited to particular applications that ensure maximum efficiency, good duty cycles and a long working life.

Our sales engineers are available to discuss particular requirements and offer a wide range of suitable, professional recommendations.

Bushey Hall Winchmaster sales@bhwgroup.co.uk www.bhwgroup.com

Southern Office: Lismirrane Industrial Park, Elstree Road, Elstree, Herts, WD6 3EE Tel: +44 (0)20 8953 6050 Fax: +44 (0)20 8207 5308

Northern Office: 6 South Orbital Trading Park, Hedon Road, Hull, East Yorkshire, HU9 1NJ Tel: +44 (0)1482 223 663 Fax: +44 (0)1482 218 285

Bushey Hall Winchmaster is a division of BHW Group Limited. Registered in England No. 1342461

COMPACT CWS SCAFFOLD HOISTS

CWS80 (80kg), CWS160 (160kg), CWS230 (230kg), CWS300 (300kg)

110v or 240v x 1ph AC

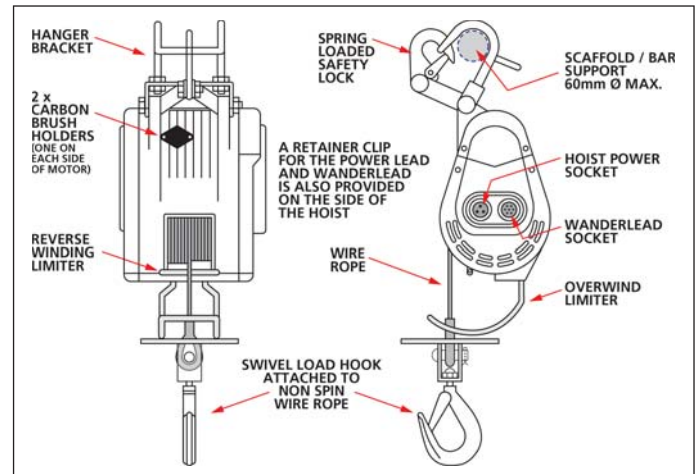

FEATURES INCLUDE

- **Available in 110v and 240v x 1ph options**
CWS80 / 160 / 230 = 110v & 240v, CWS300 = 240v
- **Fully compliant to EN 14492-2 Hoists Directive**
- **Dynamic and mechanical brake**
Provides instant, safe braking
- **Lightweight and compact design**
For easy handling and installation
- **Operates on standard 240v household power supply**
In the case of 110v version - via transformer
- **Automatic overwind limiter**
Automatically stops overwinding into the hoist casing during lifting
- **Reverse winding limiter**
To prevent the wire rope to be wound back into the casing in reverse.
- **Supplied complete with non spin wire rope**
7 x 18 wire core, galvanised finish for longer life
- **360° weighted safety hook**
Swivel type with safety catch
- **Spring loaded safety lock**
For secure attachment to scaffold
- **Motor rating IP44**
Brush type motor
- **10 metre plug in wanderlead control, rating IP65**
2 button plus emergency stop
- **5 metre power lead with commercial type 3 pin plug**
For either 240v or 110v models



CWS80

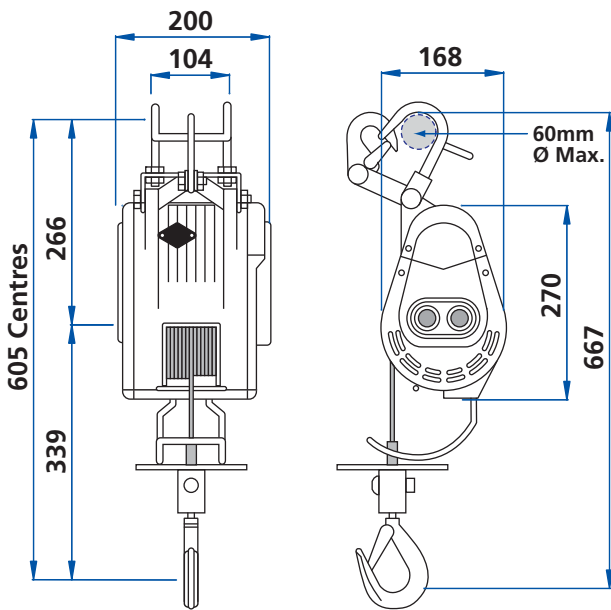

CWS160 / CWS230 / CWS300

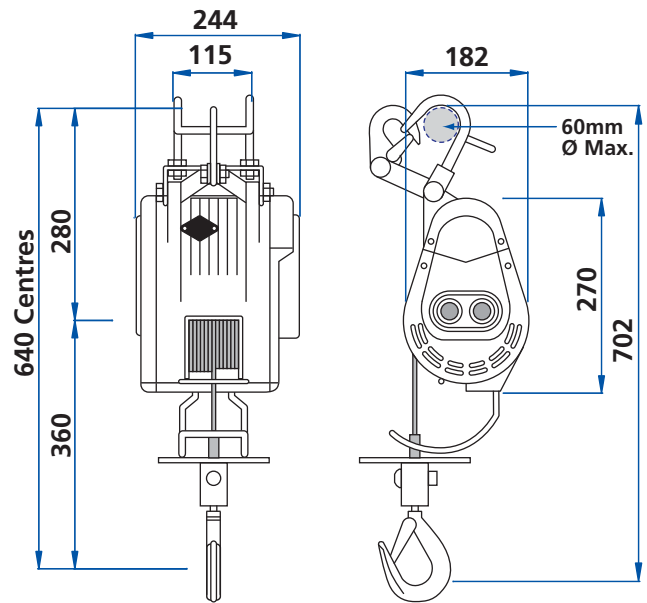

SPECIFICATIONS

CWS80

CWS160

CWS230

CWS300

Voltage:	110v	240v	110v	240v	110v	240v	240v only
Lifting: Capacity	80kg		160kg		230kg		300kg
	23m		30m		24m		24m
Weight: Hoist only	9kg		14kg		15kg		17kg
	18kg		25kg		26kg		28kg
Line speed: 1st layer	18m/min		15m/min		9m/min		9m/min
	30m/min		25m/min		14m/min		13m/min
Duty cycle:	All Scaffold Hoists have a duty cycle of 25%, with a maximum of 60 starts per hour						
Wire rope: Diameter	4mm		5mm		5mm		5mm
	24m		31m		25m		25m
Rope construction	7 x 18 wire core, spin resistant, galvanised for longer rope life. Factor of safety = 5:1						
Motor:	All Scaffold Hoists have a brush type induction motor						
Outputs: Kilowatts	0.8kw		1.2kw		1.2kw		1.5kw
	8amp	4amp	12amp	6amp	12amp	6amp	7.5amp
Braking:	Motor: Electronic via resistor			Gears: Mechanical ratchet brake			
Drum: Length	46mm		110mm		110mm		110mm
	70mm		94mm		94mm		94mm
	158mm		155mm		155mm		155mm
Rope ϕ to mean drum ϕ^*	18:1		20:1				

* Mean drum diameter = the drum diameter plus the diameter of the wire rope

NOTES

Please ensure that the fixing point for these hoists are capable of supporting the loads required.

These hoists must not be used for the movement of personnel and 5 wraps of wire rope must be maintained on the drum.

Data shown is approximate and intended as a guide only.

WARRANTY

Each new hoist is guaranteed against defects in workmanship and material defects for a period of twelve months from date of purchase.

Wire ropes are not included under warranty.

Bushey Hall Winchmaster sales@bhwwgroup.co.uk www.bhwwgroup.com

Southern Office: Lismirrane Industrial Park, Elstree Road, Elstree, Herts, WD6 3EE Tel: +44 (0)20 8953 6050 Fax: +44 (0)20 8207 5308

Northern Office: 6 South Orbital Trading Park, Hedon Road, Hull, East Yorkshire, HU9 1NJ Tel: +44 (0)1482 223 663 Fax: +44 (0)1482 218 285

Bushey Hall Winchmaster is a division of BHW Group Limited. Registered in England No. 1342461



CERT. No. 1769

WM24/15.08.12